

Series PHD/Pendant Hand-held

For CNC Panels/4 Axis/Without E-Stop



US \$330.00
S.R.P.
List Price

FEATURES

- Hand-held Pulse Generator for “manual” axis jog
- Differential Line Driver Output
- X, Y Z Selector switch with OFF position plus 4 axis
- “Handy” and “Light Weight” and “Very Thin”
- Standard 10 ft. extended spiral cable

FANUC CNC model available

#EPG-B-A-4-S \$400.00 S.R.P.

SPECIFICATIONS

Electrical

Outputs	Line Driver	TTL Voltage Output for FANUC
Pulse per Revolution	100 PPR	
Supply Voltage	5 v±0.25 v dc	5 v±0.25 v dc
Output Voltage (VH)	≥2.5 v	≥4.0 v
Output Voltage (VL)	≤0.5 v	≤0.5 v
Current Requirement	≤60 mA (No Loading)	
Sink Current	≤20 mA	
Output Capacity	Sync. Current: 20 mA, Residual Voltage: ≤0.5 v	
Phase Difference	Quadrature Square Wave A & B: 90°±45° (T/4±T/8)	
Rise/Fall Time	≤2 μs	
Frequency Response	0-10 kHz	
Insulation Resistance	20 MΩ At 500 v dc Megger (Circuit-Body)	

Mechanical

Dial Rotating Speed	500 r/min.-Max., 200 r/min.-Normal (Continuous)
Starting Torque	8.34 ozf-in (600 gf-cm) at 25°C
Rotational Life	10x 6 bits turns at ≤ 200 rpm
Weight	2.2 lbs (1 kg)

Environmental

Operating Temperature	0° to 60° C
Humidity	RH 35% to 90% no condensation
Storage Temperature	0° to 80° C
Vibration	10-50 Hz/1.5mm X, Y, Z - 2 hrs. each
Shock	50 G per 11 ms
Enclosure	IP64/NEMA 4

Rotary Switch

Max. Voltage	28 v dc
Current	10 mA
Operating Torque	0.005-0.02 Nm

OUTPUT WAVE FORMS

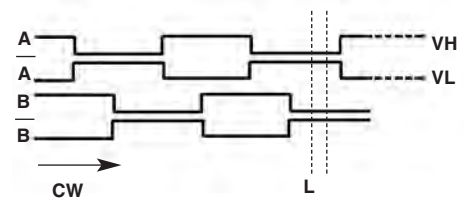

Relation between output signals and click stop position.

OUTPUT CIRCUIT

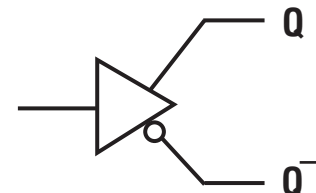

26LS31 or equivalent

Recommended line receiver: 26LS32

Series PHD / Pendant Hand-Held / 4 Axis without E-Stop

MODEL NUMBER	SPECIFICATION	LIST PRICE
PHD-100-B-S	100 Pulse, 5v DC, Linedriver Output, Quadrature Dual Channels. Two (2) Mode Switches. (4 axis and multiplier) 3m (10 ft.) Spiral Cable	\$330.00
EPG-B-A-4-S	For FANUC CNC, 5v DC, TTL Output, Quadrature Dual Channels. Two (2) Mode Switches. (4 axis and multiplier) 3m (10 ft.) Spiral Cable	\$400.00

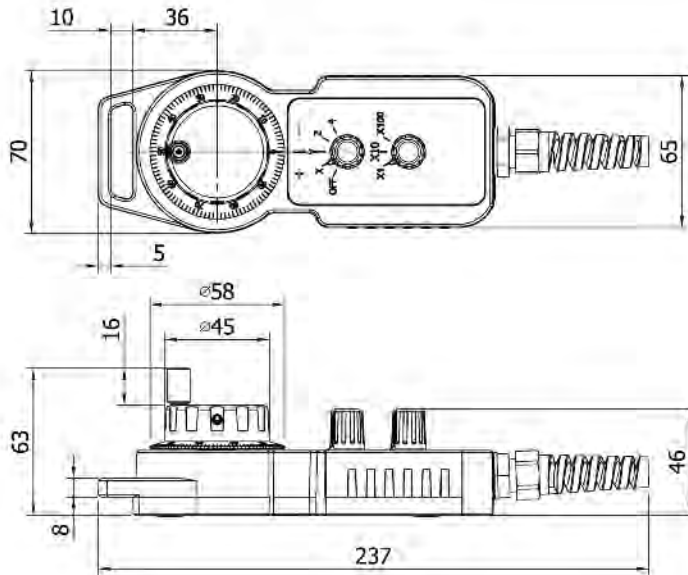

Including Hook Bracket

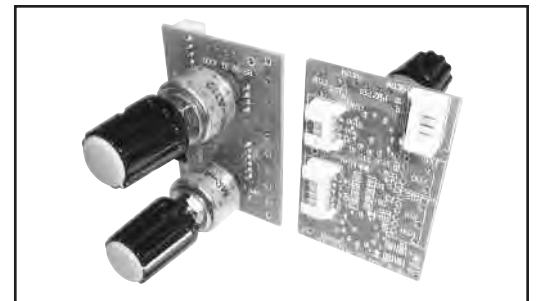
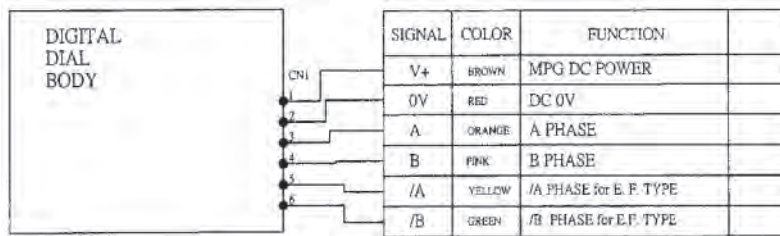

Replacement (2) Selector SW's w/PCB - D.I.Y. work

Model	Price
H1-00125-001	\$96.00

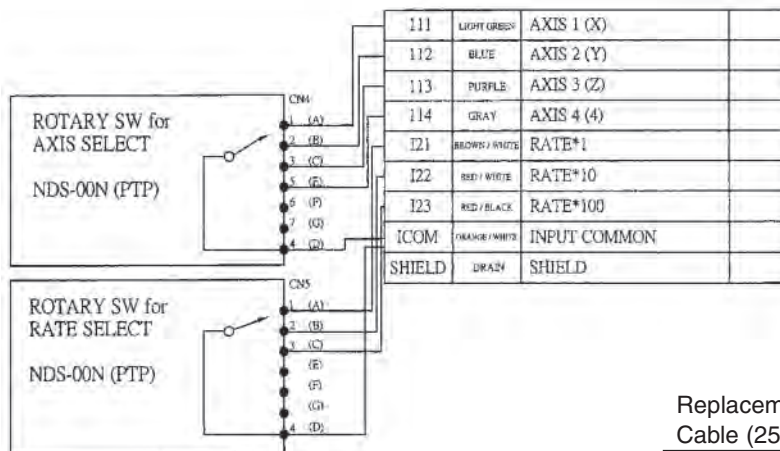

Replacement 5m (16ft.) Spiral Cable (25 wires) - D.I.Y. work

Model	Price
EE-6C004-A01	\$120.00

